

# UVL-Based Prompt Variability for AI Agents in UX design processes

**Guillermo Ciria González**

Miguel Ángel Olivero González

Francisco José Domínguez-Mayo





- **Context**

- Methodology as an UVL model

- UVL usage as a translation tool

- Agent workflow

# 1. Context



- Context
- **Methodology as UVL model**
- UVL usage as a translation tool
- Agent workflow

# 2. Methodology as UVL model

## Model Information

**Average Branching**

**Factor:** 2.46

---

**Leaf Number:** 39

**Estimated Number of**

**Configurations:** 90715

---

**Max Depth:** 4

**Atomic Sets:**

[Show Details](#)

---

**Core Features:**

**Leaf Features:**

[Show Details](#)

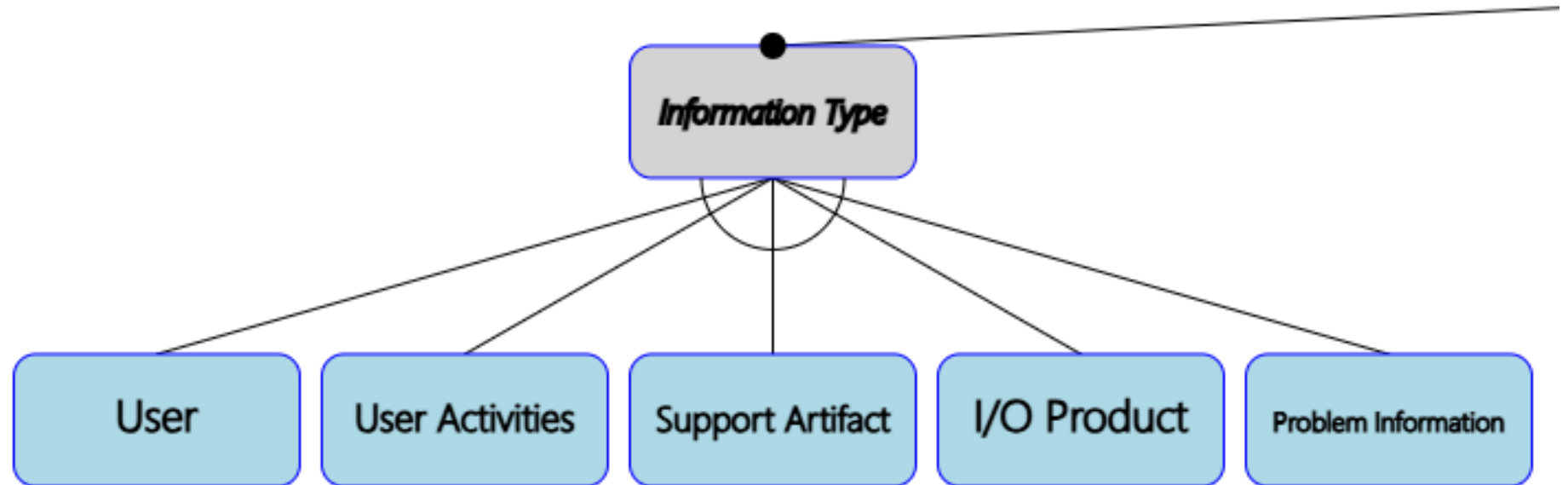

## 2. Methodology as UVL model

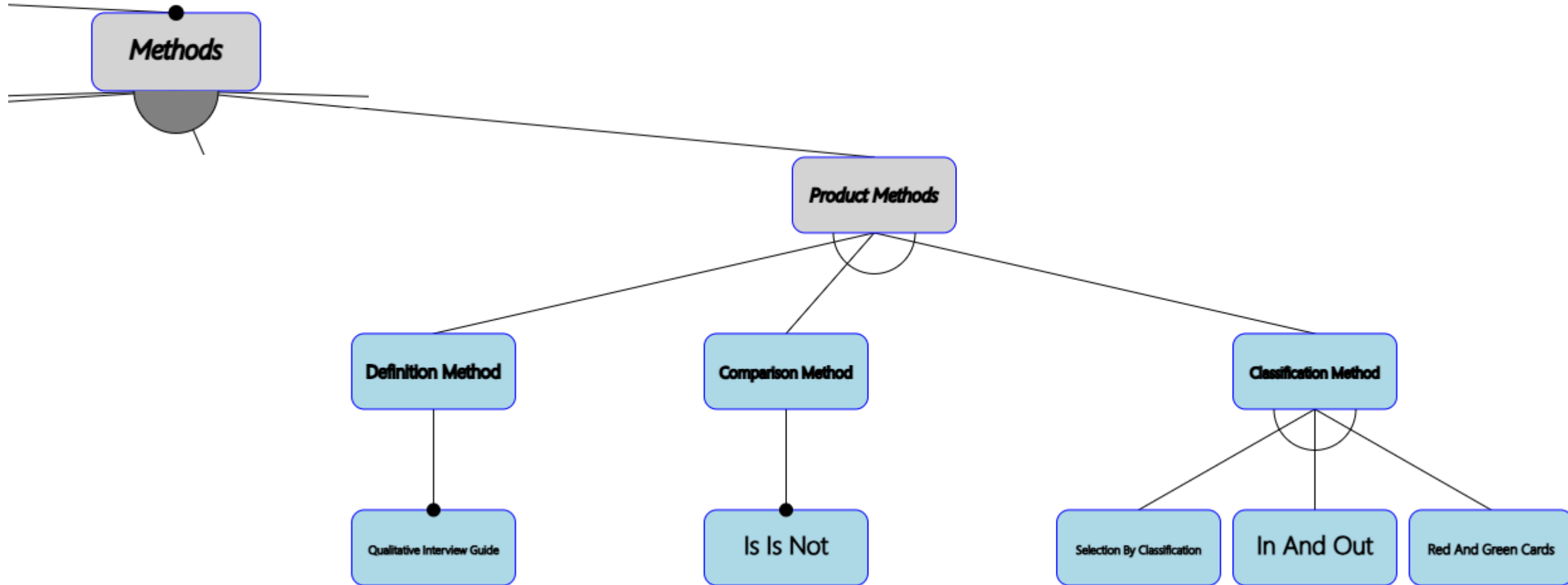

- Context
- Methodology as UVL model
- **UVL usage as a translation tool**
- Agent workflow

### 3. UVL usage as a translation tool

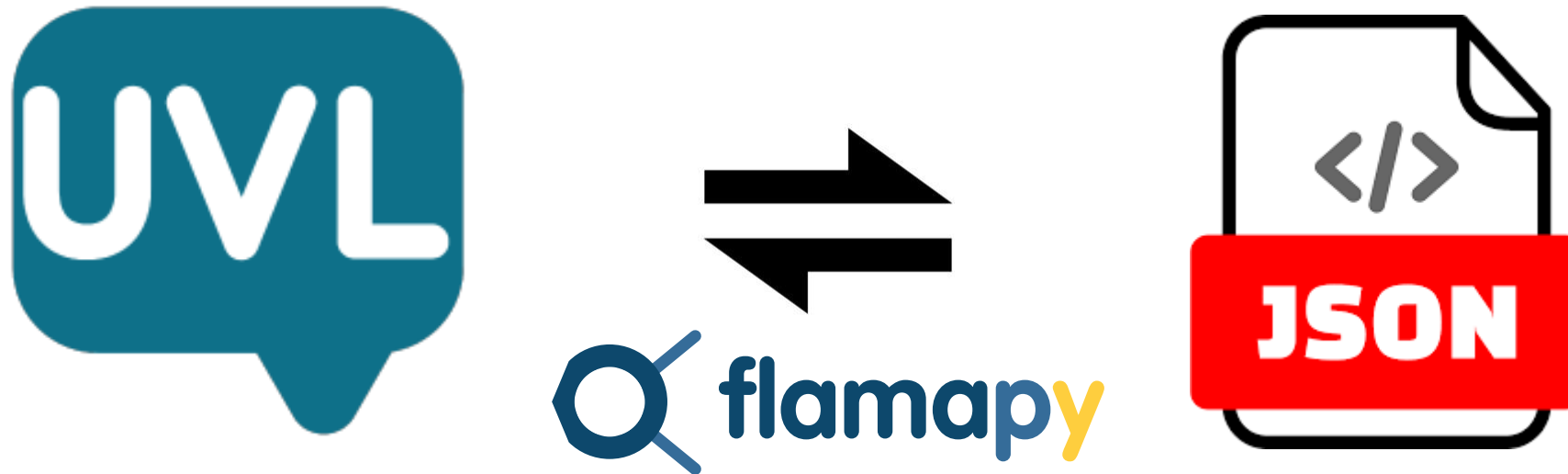

### 3. UVL usage as a translation tool



- Context
- Methodology as UVL model
- UVL usage as a translation tool
- **Agent workflow**

# 4. Agent workflow

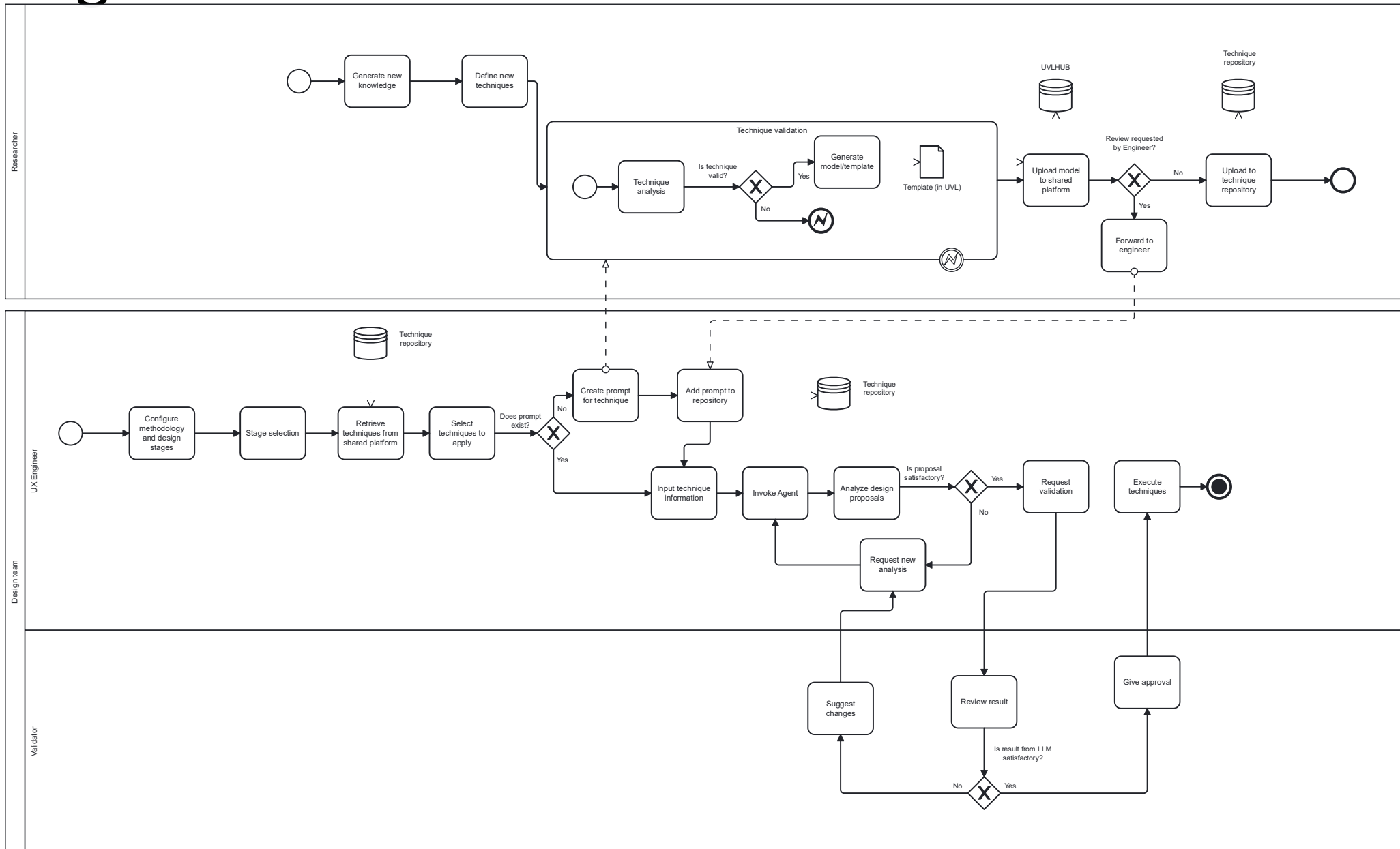

# 4. Agent workflow

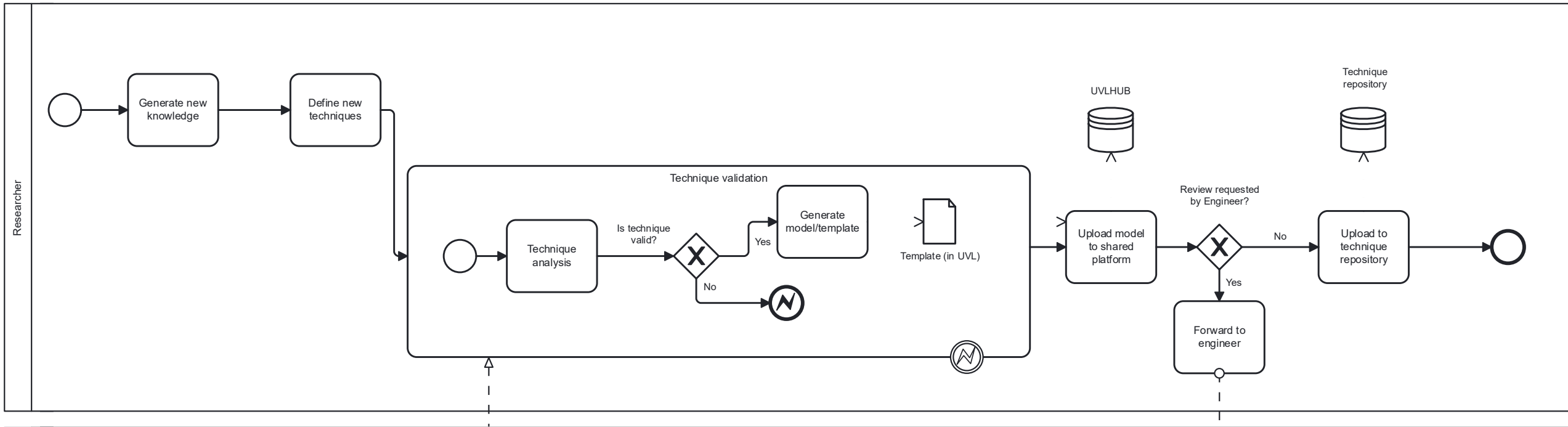

# 4. Agent workflow

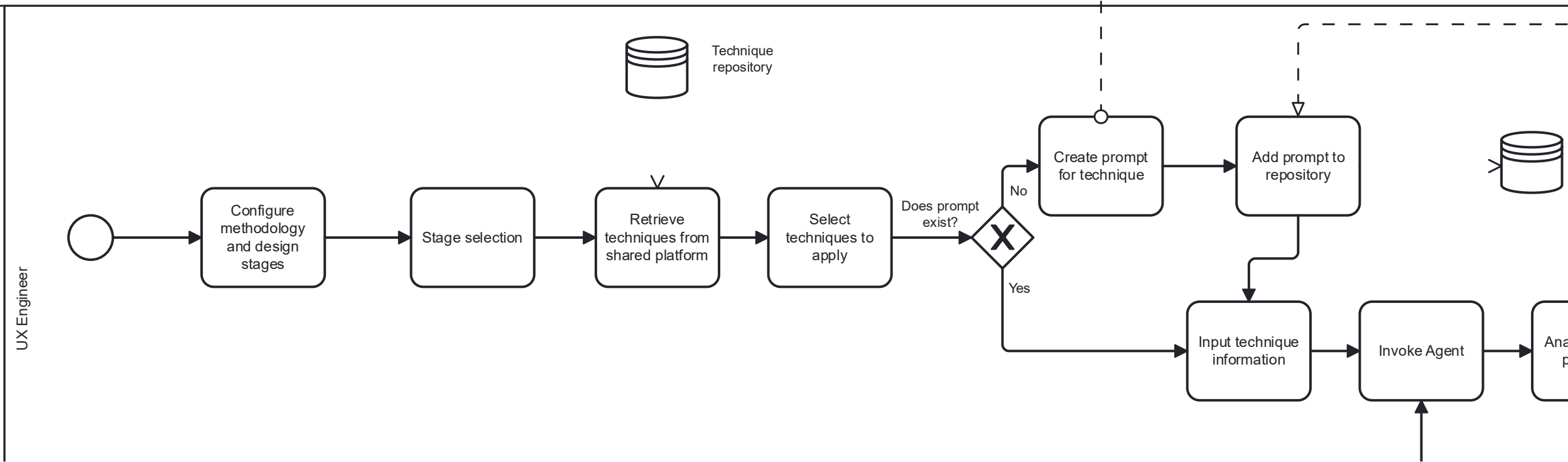

UX Engineer

# 4. Agent workflow

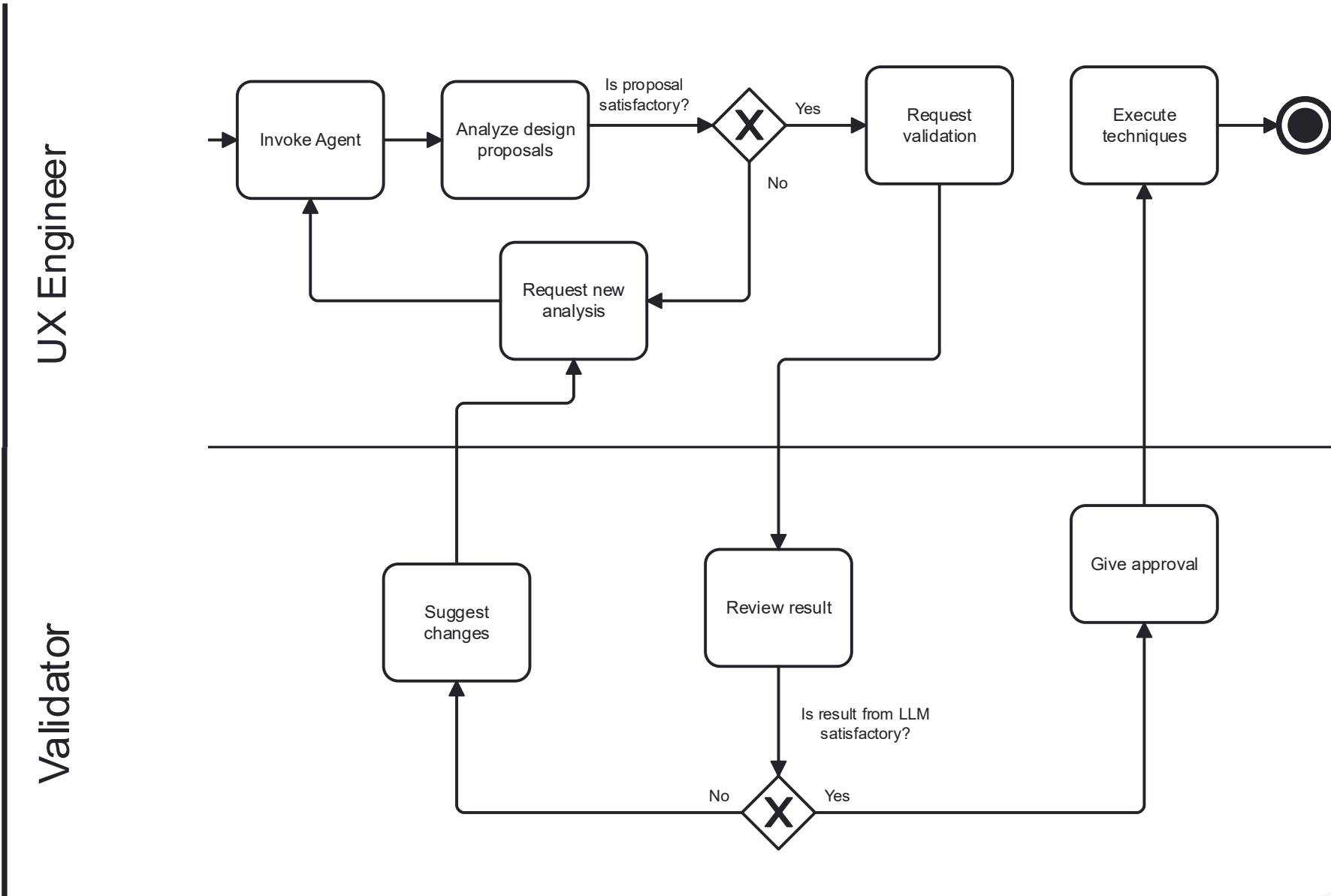

# 4. Agentic workflow

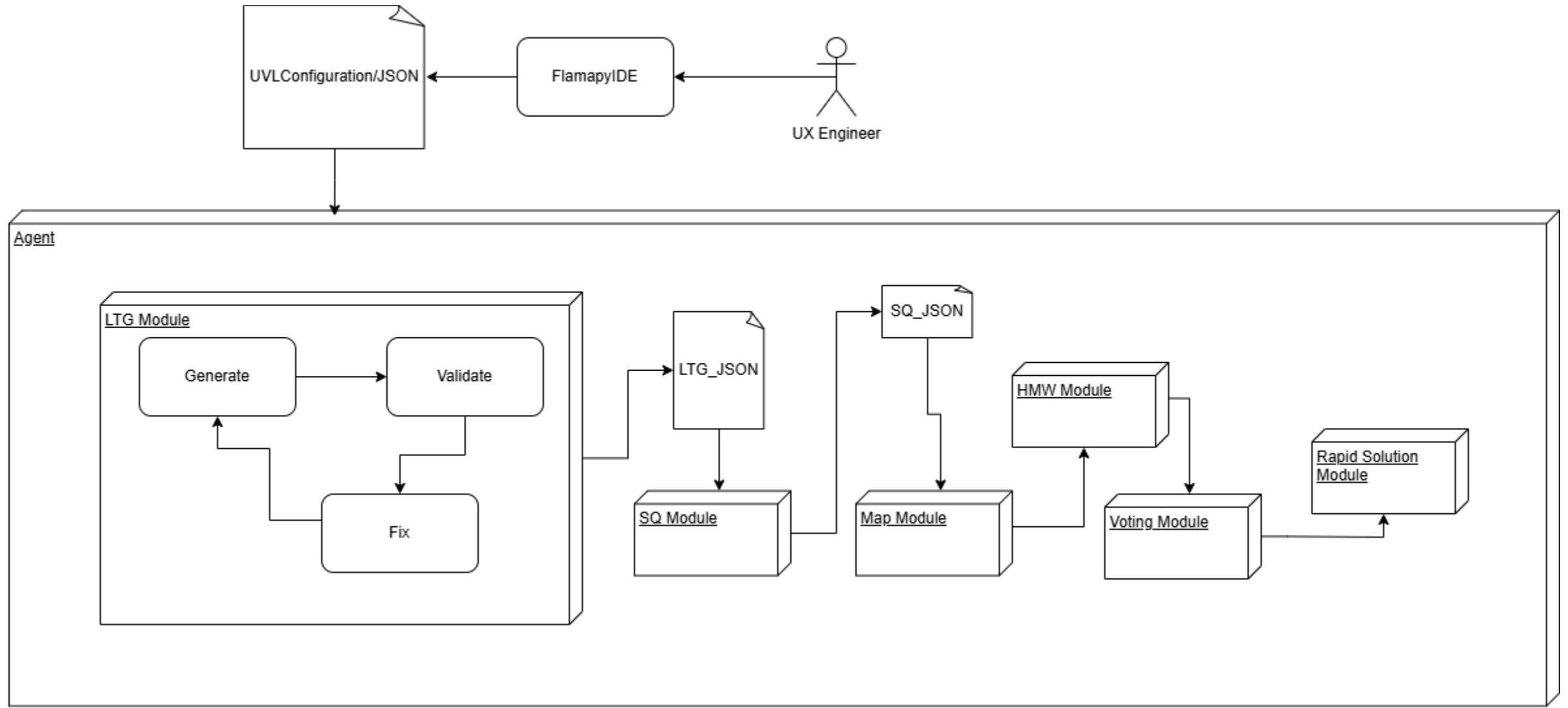

# UVL-Based Prompt Variability for AI Agents in UX design processes

**Guillermo Ciria González**

Miguel Ángel Olivero González

Francisco José Domínguez-Mayo

